

C7.1 Marine Propulsion Engine

Commercial Applications

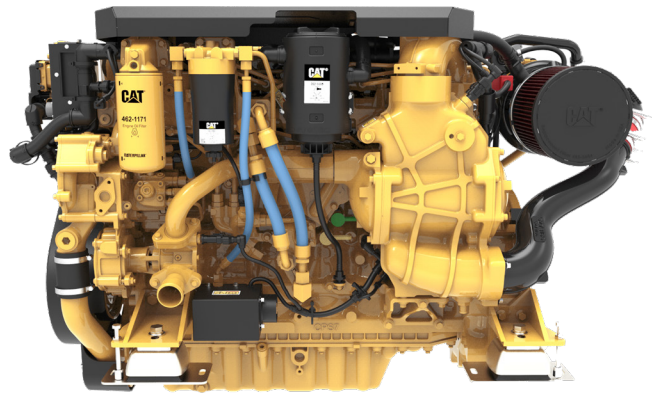
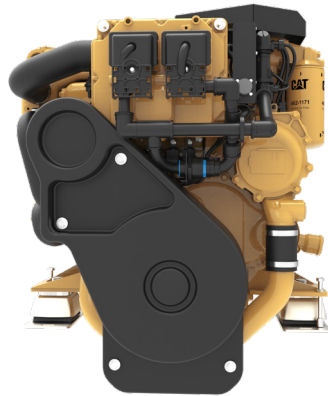

ENGINE SPECIFICATIONS

CONFIGURATION	In-line 6, 4-stroke cycle diesel
EMISSIONS	U.S. EPA Tier 3, IMO II, RCD II, China II
RATED ENGINE SPEED	2300 rpm - 2700 rpm
DISPLACEMENT	7.01 L (428 cu in)
ASPIRATION	Turbocharged - aftercooled
GOVERNOR	Electronic (A5E2 V2 ECM)
FLYWHEEL HOUSING	SAE No. 03

BORE x STROKE	105 mm x 135 mm / 4.13 in x 5.31 in
REFILL CAPACITY LUBE OIL SYSTEM W/ OIL FILTER CHANGE	20 L (5.3 gal)
OIL CHANGE INTERVAL	500 hrs
ROTATION (from flywheel end)	Counterclockwise from the flywheel end
COOLING	Heat exchange or keel cooled

KEY FEATURES & BENEFITS

- Common rail fuel system enables optimum combustion and low emissions
- Reduced combustion noise through advanced electronic control
- 12V or 24V electrical system
- Compatible with Cat® displays and electronics
- Closed crankcase ventilation system improves engine room cleanliness
- Gear-driven jacket water pump and sea water pump for superior reliability
- Maintenance free valve train with hydraulic valve lash adjusters
- Self-priming fuel system ensures a smooth start every time

STANDARD EQUIPMENT

- Water-cooled turbocharger and exhaust manifold
- Common rail fuel system
- Corrosion-resistant sea water aftercooler
- Closed crankcase ventilation system
- Starter motors – 12V or 24V
- Fuel cooler
- Integral engine oil cooler
- Vibration damper and guard
- Electric fuel priming pump
- Self-tensioning multi-vee alternator drive belt
- Gear-driven seawater pump (rubber impeller)
- Fin and tube-type jacket water heat exchanger
- Front and rear engine mounting brackets

OPTIONAL ATTACHMENTS

- Marine Classification Society (MCS) Approval
ABS, BV, CCS, CRS, *DNV-GL, IRS, LR, Class NK, PRS, RINA
(*DNV-GL approval available for keel-cooled engines only)
- SOLAS double wall high-pressure fuel lines
- Engine mounted bilge pumps and auxiliary water pumps with electromagnetic clutch
- Engine-mounted secondary alternator – 24V 55 amp or 12V 100 amp
- Analogue gauge displays
- Transmission gear oil cooler (engine mounted)
- Glow plugs
- Jacket water heater
- Various 5" and 6" water cooled exhaust elbow configurations
- Cabin heater (calorifier) connections
- Right-hand and high-level left-hand oil dipsticks
- Mechanical throttle converter for repower

RATINGS & FUEL CONSUMPTION

IMO II

Rating	mhp	bhp	bkW	rpm	U.S. g/h	g/bkW-hr	IMO	U.S. EPA	EU	China
B	284	280	209	2300	14.9	215.1	II	T3C	RCD	C-II
C	355	350	261	2500	18.3	211.5	II	T3C	RCD	C-II
D	406	400	298	2600	20.3	206.1	II	T3C	RCD	C-II
D	431	425	317	2700	22.9	215.6	II	T3C	RCD	C-II

ISO 3046/1 BSFC tolerance of -0/+5%

Rating Definitions:

B Rating (Heavy Duty): Typical applications: For vessels operating at rated load and rated speed up to 80% of the time with some load cycling (40% to 80% load factor). Typical operation ranges from 3000 to 5000 hours per year.

C Rating (Maximum Continuous): Typical applications: For vessels operating at rated load and rated speed up to 50% of the time with cyclical load and speed (20% to 80% load factor). Typical operation ranges from 2000 to 4000 hours per year.

D Rating (Intermittent Duty): For vessels operating at rated load and rated speed up to 16% of the time (up to 50% load factor). Typical operation ranges from 1000 to 3000 hours per year.

ENGINE DIMENSIONS & WEIGHT

LENGTH	43.1 in / 1,095 mm
HEIGHT	34.5 in / 876 mm
WIDTH	31.4 in / 798 mm
DRY WEIGHT	1,676 lb / 760 kg

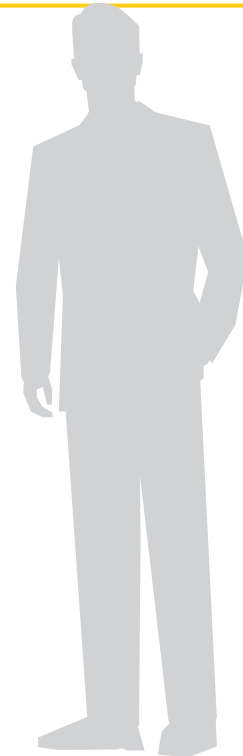
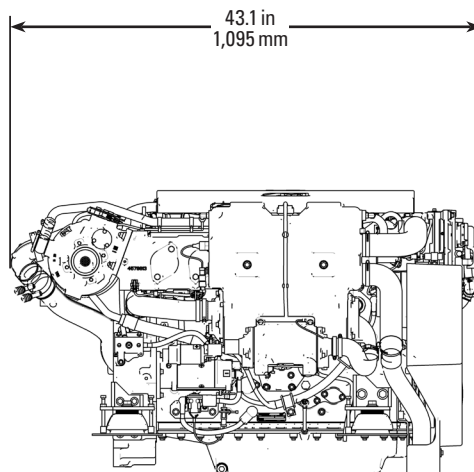
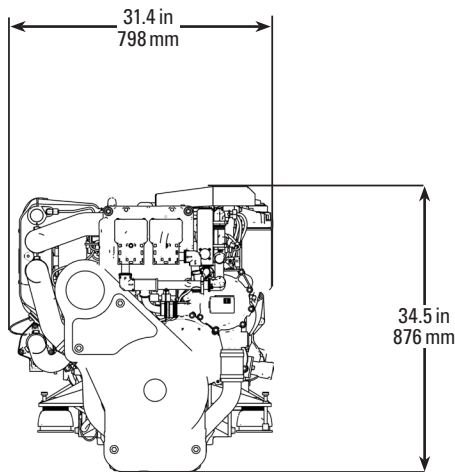

Contact your local Cat® Dealer for more information!

LEHM21398-01

© 2023 Caterpillar. All Rights Reserved. CAT, CATERPILLAR, LET'S DO THE WORK, their respective logos, "Caterpillar Corporate Yellow", the "Power Edge" and Cat "Modern Hex" trade dress as well as corporate and product identity used herein, are trademarks of Caterpillar and may not be used without permission.

